

### The Semiconductor Diode

The semiconductor diode is a device that will conduct current in one direction only. It is the electrical equivalent of a hydraulic check valve. The semiconductor diode has the following characteristics:

- A diode is a two-layer semiconductor consisting of an *Anode* comprised of *P-Type* semiconductor material and a *Cathode* which is made of *N-Type* semiconductor material.
- The P-Type material contains charge carriers which are of a positive polarity and are known as *holes*. In the N-Type material the charge carriers are *electrons* which are negative in polarity.
- When a semiconductor diode is manufactured, the P-Type and N-Type materials are adjacent to one another creating a P-N Junction.

### Biasing

A bias refers to the application of an external voltage to a semiconductor. There are two ways a P-N junction can be biased.

- A forward bias results in current flow through the diode (diode conducts). To forward bias a diode, a positive voltage is applied to the Anode lead ( which connects to P-Type material) and the negative voltage is applied to the Cathode lead ( which connects to N-Type material).
- A reverse bias results in no current flow through the diode (diode blocks). A diode is reverse biased when the Anode lead is made negative and the Cathode lead is made positive.

### P-N Junction Characteristics

The P-N Junction region has three important characteristics:

- 1) The junction is region itself has no charge carriers and is known as a *depletion region*.
- 2) The junction (depletion) region has a physical thickness that varies with the applied voltage. A forward bias decreases the thickness of the depletion region; a reverse bias increases the thickness of the depletion region.
- 3) There is a voltage, or potential hill, associated with the junction. Approximately 0.3 of a volt is required to forward bias a germanium diode; 0.5 to 0.7 of a volt is required to forward bias a silicon diode.

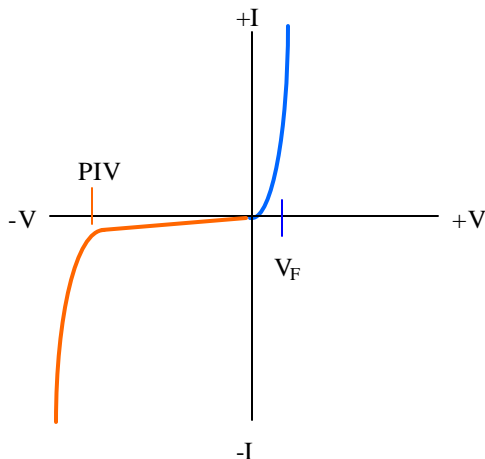

Diode X-Y Characteristic Curve

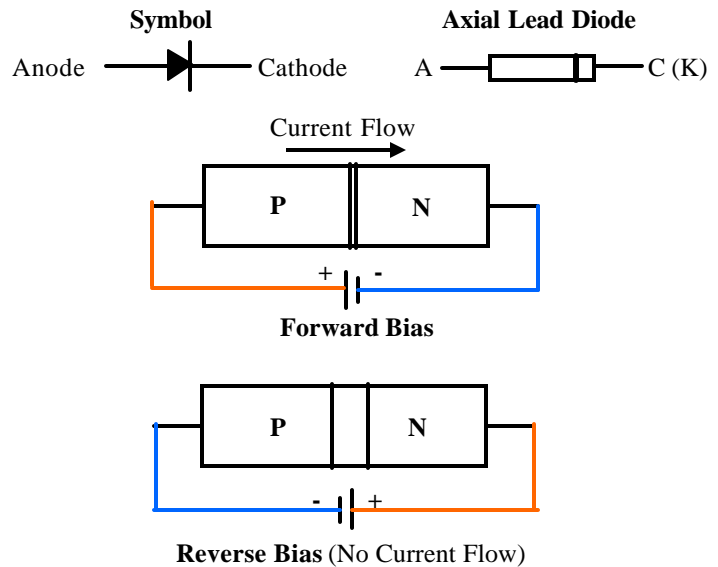

**Ratings**

Three characteristics must be defined for proper application or replacement of a semiconductor diode:

**Voltage Rating** is the maximum voltage which the diode will *block* in the reverse-biased mode.

- This is expressed as the Peak-Reverse-Voltage (PRV) or Peak-Inverse-Voltage (PIV).
- It is important to remember that this is a *peak* value of voltage not the *root-mean-square* (RMS) value. As a “Rule-of-Thumb, to provide a margin of safety, the PIV rating of a diode should be at least 3 times the RMS voltage of the circuit.

**Current Rating** is the maximum current the device can carry in the forward biased direction.

**Package Configuration**

- Small, low current diodes are available in an axial lead configuration. The band end is the cathode.
- High current diodes come in a press-fit, stud- mounted, or hockey puck package. Stud mounted diodes are available in Standard Polarity (stud cathode) and Reverse Polarity (stud anode).

**Thermal Limits**

- It is essential that semiconductors operate within the device temperature ratings.
- Semiconductor charge carriers are released thermally as well as electrically. Heat-sinking may be required during soldering and when the device is in operation to prevent thermal damage.
- The forward resistance of a diode decreases with temperature; this results in an increase in current, which in turn produces more heat. As a result, *thermal run-away* can occur and destroy the semiconductor.

**CROSS SECTION OF SILICON DIODE**

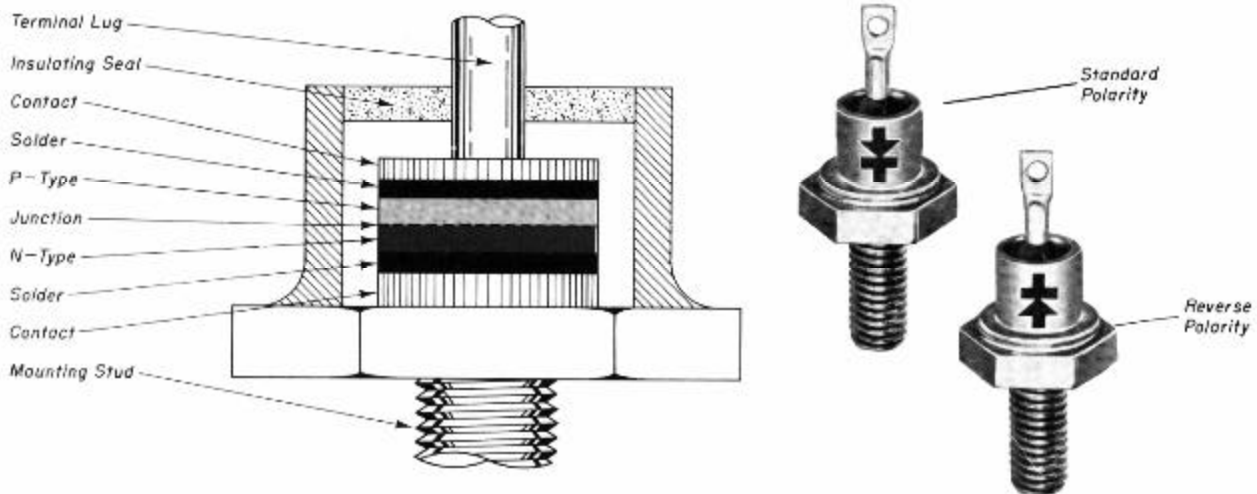

THE PN CRYSTAL is soldered between contacts and contained in a hermetically sealed case. Stud provides for mounting on a suitable fin or other heat sink for adequate cooling. Diode shown is standard polarity type. Terminal lug is anode (positive connection) and stud is cathode. Reverse diode provides opposite polarity of lug and stud.

TPI 183 Digital Multimeter



Unlike its predecessor, the Analog Ohmmeter, Digital Ohmmeters require a special Diode Check Function because the current circulated by the normal Ohms Function of a digital meter is too low to adequately check a diode.

In the Diode Check Position, the reading given by a digital meter in the forward bias direction (meter positive to diode anode and meter negative to diode cathode) is actually the voltage required to overcome the internal diode junction potential. For a silicon diode this will be about 0.5 - 0.8 volt; a germanium diode will read slightly lower, about 0.3 - 0.5 volt.

Symbol Notation K (or C) = Cathode, A = Anode.

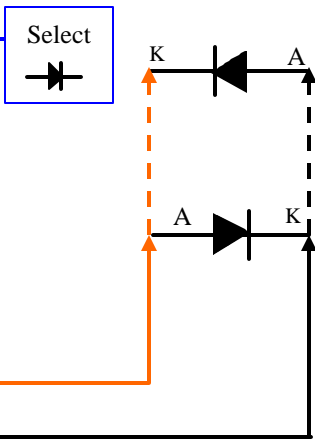

Reverse Bias - Diode Blocks  
Correct reading: TPI Meter will read OUCH for open circuit indication. (Some meters read OL.)

Forward Bias - Diode Conducts.  
Correct reading: Meter will read about 0.5 - 0.8 volt.

Incorrect Readings: If meter reads 0 both directions, it is shorted. If it reads OUCH (open circuit) both directions, it is open.

Diodes

Diode Test Procedure

Caution: Ohms and Diode Check measurements can be made *only* on *de-energized* circuits! The Ohmmeter battery provides power to make this measurement. You may need to remove the diode from the circuit to get a reliable test. See Note below.

- Connect leads to meter as shown - Black COM, Red W .
- Select the (Diode Test) function.
- Connect the leads to the Diode-Under-Test as shown in the drawing above and verify the readings are correct for both a forward and reverse bias. (This is sometimes referred to as checking the front-to-back ratio.)

Note: Large Stud-Mounted Diodes are bolted to a heat sink and Hockey Puck Units are compressed between the heat sinks; removing them from the circuit can be time-consuming and may be unnecessary. In these situations, test the entire assembly first, then, if the assembly tests shorted, remove and test the diodes individually. Hockey Puck Diodes must be compressed in a heat sink assembly or test fixture to be tested as they require compression to make-up the internal connections.

Rectification

- Rectification is the process of converting an Alternating Current (AC) to a Direct Current (DC).
- In the circuits below, the DC output voltage is defined as pulsating DC because it has the same waveform as one-half cycle of the applied alternating current. It is DC because it always has the same polarity with respect to zero volts. On single-phase rectifiers, the output DC voltage goes to zero after each rectified half cycle.
- To convert a pulsating DC to a pure DC, such as that produced by a battery or DC generator, the DC output voltage must be filtered.
- The diode symbol points in the direction of conventional current flow (positive to negative).
- To analyze the operation of a rectifier circuit supplied by an AC circuit, arbitrarily assign a polarity to the transformer winding and analyze the diode operation, then reverse the polarity assignment and again analyze the operation of the diode. When the anode of the diode is made positive *with respect to* the cathode the diode will conduct. When the anode of the diode is made negative *with respect to* the cathode the diode will block the flow of current.
- When the diode is *conducting*, current flows through the diode and the voltage drop across the diode is very small (typically 0.5 - 0.7 volts for a silicon diode). The current flow through the load resistor produces a voltage drop across the load resistor.
- When the diode is *non-conducting*, no current flows through the diode and the applied voltage appears across the diode. Because there is no current flow, there will be no voltage drop across the resistor.

Rectifiers

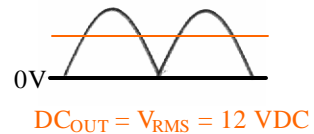
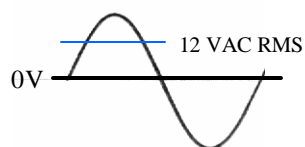
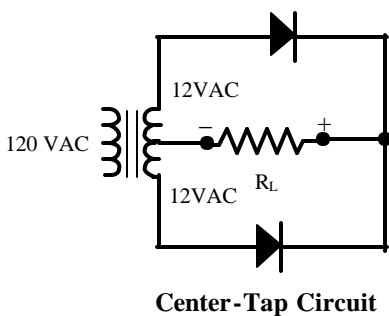
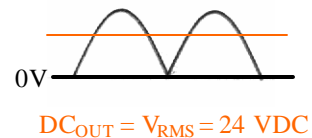
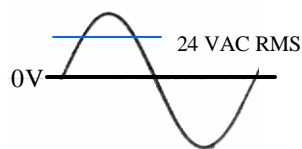
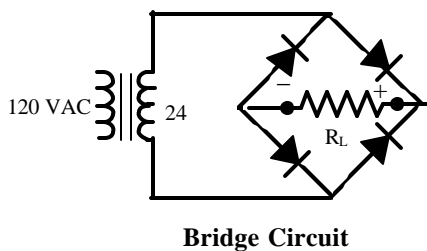
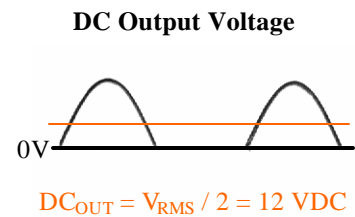
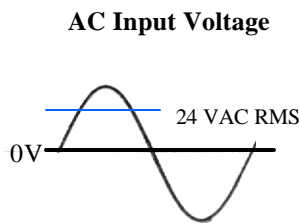
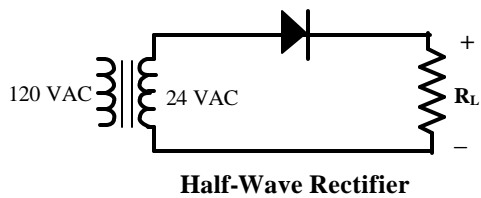

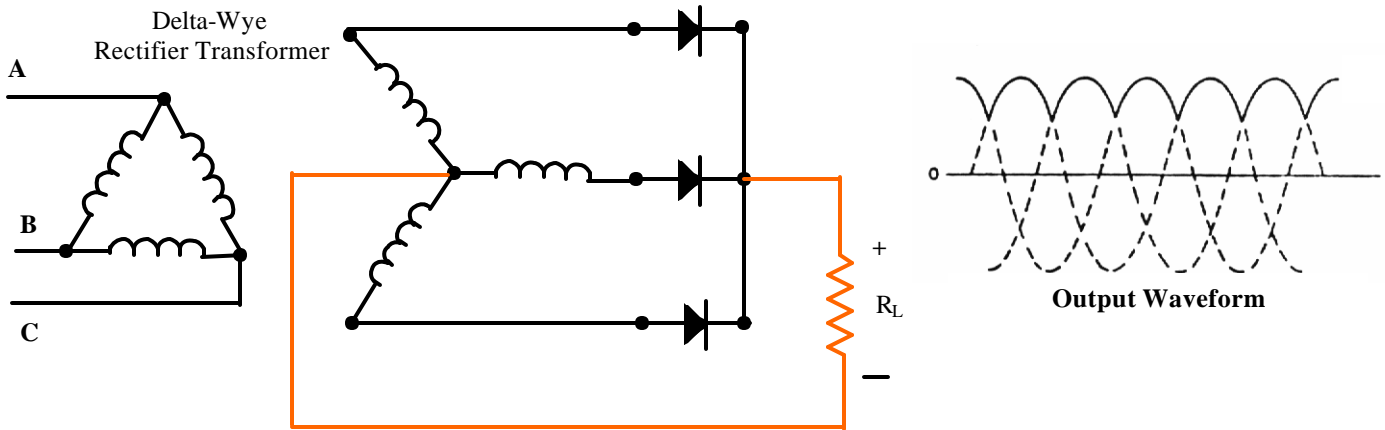

**Three-Phase Half-Wave Rectifier**

On three-phase rectifiers, the pulsations do not return to zero as with a single phase rectifier. This reduces the amount of ripple and simplifies filtering.

A diode is forward biased when the anode is made more positive *with respect to* the cathode. Each of the diodes is forward biased when the voltage of the phase leading it becomes lower than the diode anode voltage and the diode is reverse biased when the voltage of the phase lagging it becomes higher than that diode anode voltage.

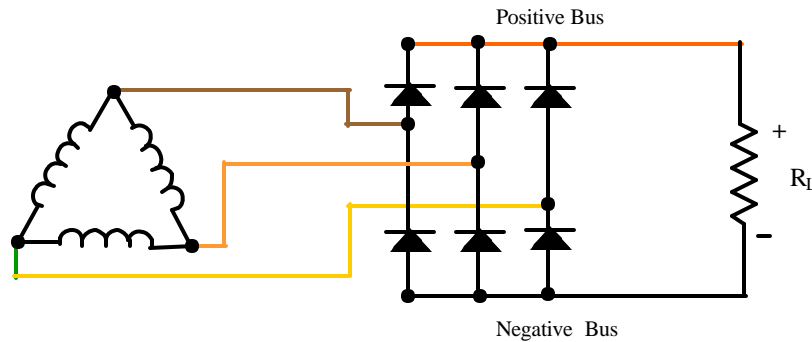

**Three-Phase Full-Wave Rectifier**

Showing rectifier transformer delta secondary only. When the diodes are replaced with SCR's, the output voltage of the rectifier can be controlled by phase-firing of the SCR's. This arrangement is referred to as a six-pulse system.

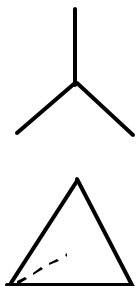

**Six-Phase Systems**

Some special medium-voltage rectifier transformers have dual secondary windings - one delta, the other wye - which are 30 degrees out-of-phase. The phase-to-phase voltage of the wye matches the phase voltage of the delta. The outputs are individually rectified and the rectifiers are connected in series, resulting in a six-phase system with very low ripple, that has an output voltage which is double the voltage of the individual windings. The dashed line in the corner of the delta shows the phase shift between the two windings.